

1-1/2" X 1/4" THK.  
STEEL FLATBAR

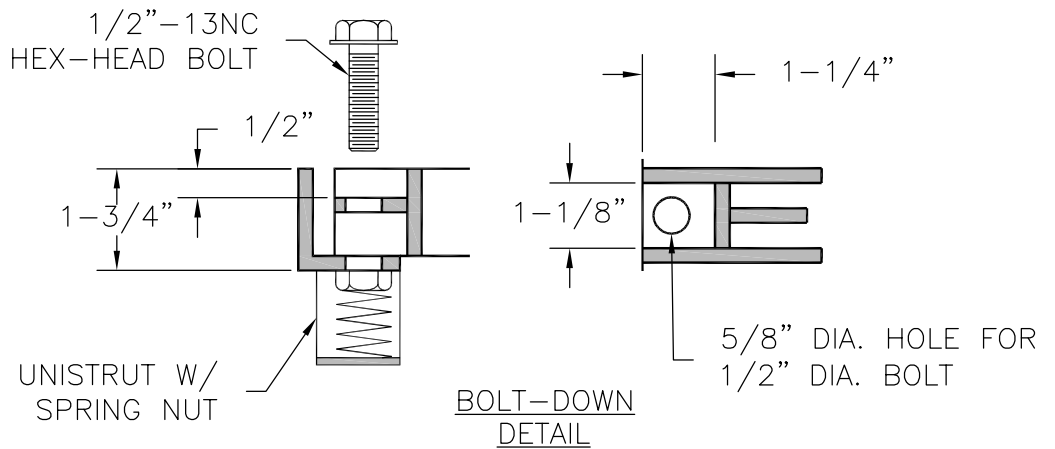
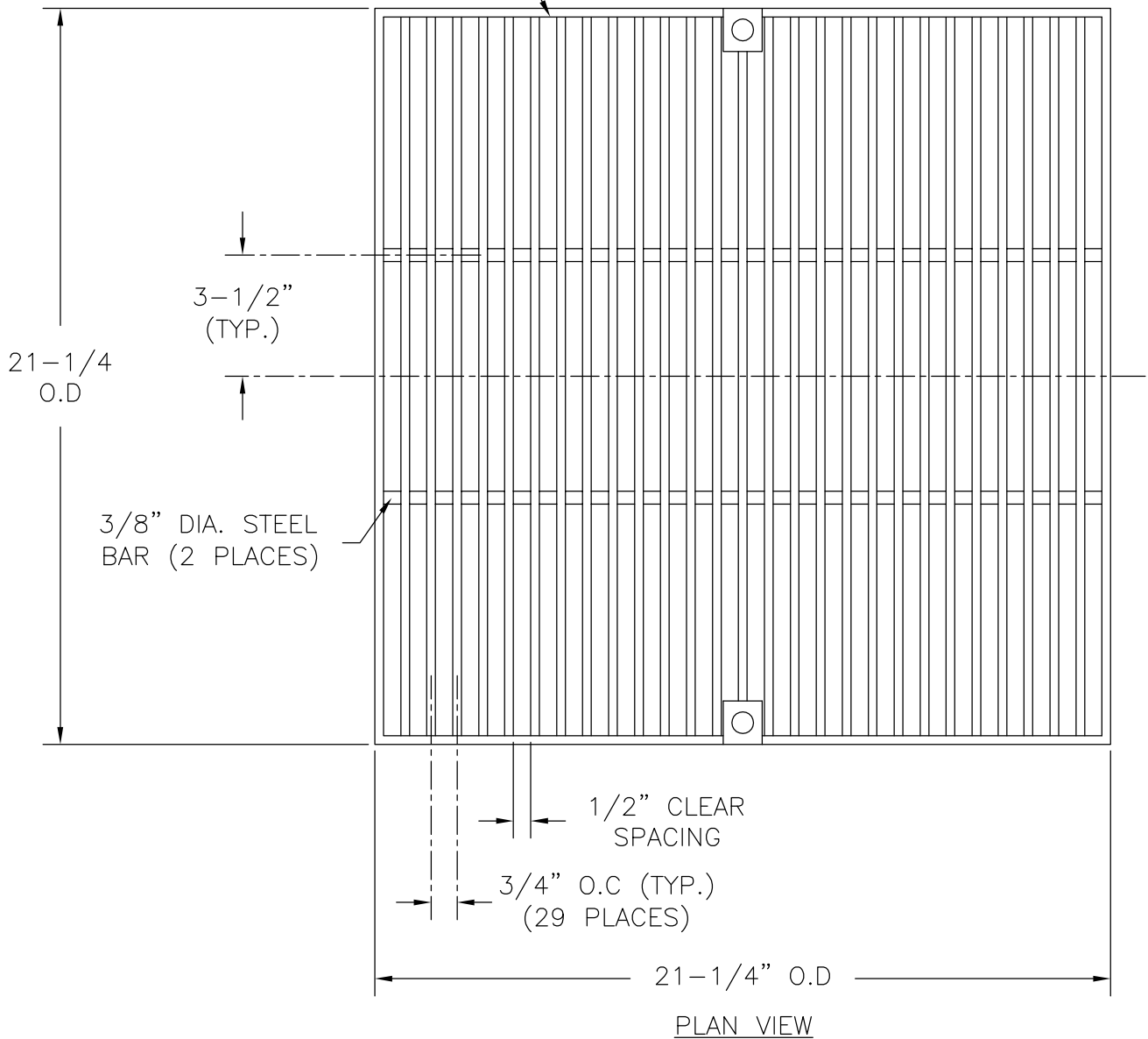

### 18" X 18" STEEL TRAFFIC GRATE per ADA SPECIFICATIONS

1. All steel shall conform to ASTM A36.
2. Grate conforms to ADA requirements.
3. Galvanizing is available upon request.
4. Structures are designed for AASHTO H-20 Wheel Loading.