

VINYLTECH AWWA C900 PURPLE

TECHNICAL DATA SUBMITTAL



CONFORMANCE

These specifications designate the requirements for manufacturing and installing Vinyltech AWWA C900 PVC Pressure Pipe for reclaimed water (4" – 24").

ANSI/AWWA C900 - Polyvinyl Chloride (PVC) Pressure Pipe and Fabricated Fittings, 4 in. Through 60 in. (100mm Through 1500mm)

AWWA C605 - Underground Installation of Polyvinyl Chloride (PVC) Pressure Pipe and Fittings for Water

ASTM D1784 - Standard Specification for Rigid Poly (Vinyl Chloride) (PVC) Compounds and Chlorinated Poly (Vinyl Chloride) (CPVC) Compounds

ASTM D3139 - Standard Specification for Joints for Plastic Pressure Pipes Using Flexible Elastomeric Seals

ASTM F477 - Standard Specification for Elastomeric Seals (Gaskets) for Joining Plastic Pipe

PIPE COMPOUND

The pipe shall be extruded from compounds meeting (PVC1120) the requirements of Cell Classification 12454, as defined in ASTM D1784, Standard Specification for Rigid Poly (Vinyl Chloride) (PVC) Compounds and Chlorinated Poly (Vinyl Chloride) (CPVC) Compounds.

PIPE

Vinyltech pipe shall be manufactured in accordance with AWWA C900.

GASKET JOINT

The gasket shall be reinforced with a steel band and meet the requirements of ASTM F477. Vinyltech pipe shall have an integral bell end with a locked-in factory installed gasket and shall meet the joint requirements of ASTM D3139.

MARKING

Vinyltech AWWA C900 Purple Pressure Pipe is marked in accordance with AWWA C900. The pipe is marked with two identical print lines on opposite sides of the pipe. Both sides shall include "NOT FOR POTABLE USE". The UL, FM, and NSF designations do not apply and are not printed on purple pressure pipe.

QUALITY CONTROL

Each length of the pipe including the bell shall be hydrostatically tested in accordance with AWWA C900. The pipe shall meet all additional test requirements as described in AWWA C900. Our full-time quality assurance staff continually administers a rigid program of tests to maintain the production of the best quality pipe products available.

INSTALLATION

Recommended installation procedures of Vinyltech Corporation are outlined in AWWA C605, Underground Installation of Polyvinyl Chloride (PVC) Pressure Pipe and Fittings for Water. The AWWA Manual M23, PVC Pipe-Design and Installation, is also an invaluable resource guide for design and installation.

TAPPING

The consistent success of tapping PVC pressure pipe is contingent upon the use of proper procedures and equipment. Vinyltech recommends strict compliance with the requirements as specified in AWWA C605.

ASSEMBLING THE PIPE

Assembly of Vinyltech purple PVC reclaimed water pipe is easily accomplished. A depth of entry mark is on each spigot end to serve as a visual check for rapid, accurate joint inspection. **Do not over insert.**

- 1) Remove any mud, sand, or other foreign matter from the belled and spigot ends of the pipe. Carefully clean the gasket area.
- 2) With a clean applicator (a brush or hand) lubricate the entire surface of the pipe from the spigot end to the depth of entry mark and the contact surface of the gasket with **Vinyltech Brand Lubricant**.
- 3) Brace the bell to avoid disturbing the already installed joints. Align the pipe, insert the spigot into the bell and push.
- 4) **Do not insert past the entry mark line.**



C900 DR 18 Pressure Class 235

NOMINAL SIZE		OUTER DIAMETER (IN)	MINIMUM WALL (IN)	FEET PER LIFT	LIFTS PER TRUCK	APPROXIMATE WEIGHT (LB/100')
(IN)	(mm)					
4	100	4.80	0.267	1020	16	251.6
6	150	6.90	0.383	440	16	521.2
8	200	9.05	0.503	200	20	903.0
10	250	11.10	0.617	240	12	1364.4
12	300	13.20	0.733	60-80	28	1935.8

C900 DR 14 Pressure Class 305

NOMINAL SIZE		OUTER DIAMETER (IN)	MINIMUM WALL (IN)	FEET PER LIFT	LIFTS PER TRUCK	APPROXIMATE WEIGHT (LB/100')
(IN)	(mm)					
4	100	4.80	0.343	1020	16	317.5
6	150	6.90	0.493	440	16	658.7
8	200	9.05	0.646	200	20	1139.7
10	250	11.10	0.793	240	12	1722.3
12	300	13.20	0.943	60-80	28	2445.5

C900 DR 25 Pressure Class 165

NOMINAL SIZE		OUTER DIAMETER (IN)	MINIMUM WALL (IN)	FEET PER LIFT	LIFTS PER TRUCK	APPROXIMATE WEIGHT (LB/100')
(IN)	(mm)					
14	350	15.30	0.612	120	12	1935.0
16	400	17.40	0.696	40/60	20	2575.0
18	450	19.50	0.780	40/60	20	3165.0
*20	500	21.60	0.864	80	8	3900.0
*24	600	25.80	1.032	60	6	5600.0

C900 DR 18 Pressure Class 235

NOMINAL SIZE		OUTER DIAMETER (IN)	MINIMUM WALL (IN)	FEET PER LIFT	LIFTS PER TRUCK	APPROXIMATE WEIGHT (LB/100')
(IN)	(mm)					
14	350	15.30	0.850	120	12	2650.0
16	400	17.40	0.967	40/60	20	3475.0
18	450	19.50	1.083	40/60	20	4340.0
*20	500	21.60	1.200	80	8	5350.0
*24	600	25.80	1.433	60	6	7650.0

*Northern Pipe Products

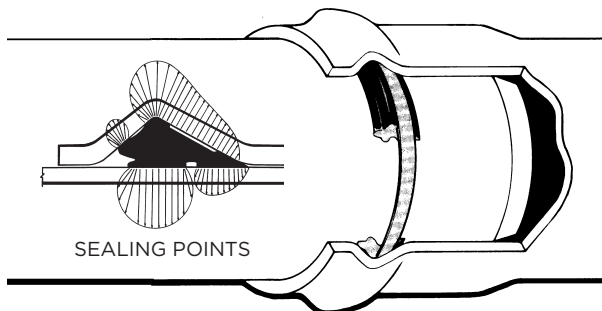

The Rieber Sealing System

The Rieber system provides a proven pipe joint with an excellent track record in the field. It is the fastest growing system in the world because of its many advantages.

- Factory installed, locked-in gasket
- The pipe bell forms over the gasket, making a perfect fit
- Avoids the possibility of installing the wrong gasket
- Reduces installation problems
- The locked-in gasket eliminates gasket roll-out during joining
- The gasket is molded vs. extruded and spliced
- Works equally well under pressure or vacuum
- Three sealing points achieved vs. two
- **LEAK-PROOF JOINTS**
- **"THE WORLDS BEST JOINT"**